

# Bergmann Dumper 2040 swivel tip

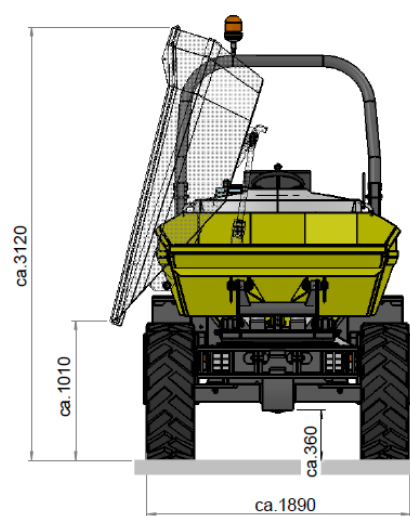

Strong arguments for  
your advantage

- ▶ high stability by  
oscillating axle
- ▶ hydraulic park brake
- ▶ instrument board  
lowerable and lockable
- ▶ type test approval  
by TBG

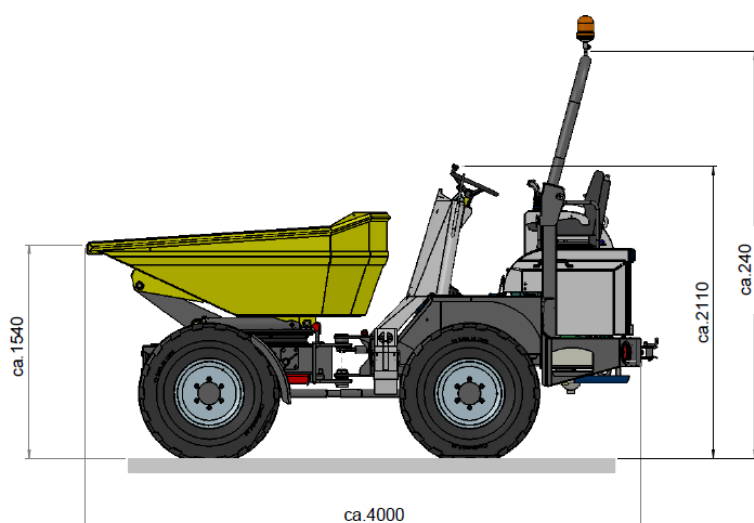



## Bergmann Dumper 2040 swivel tip

### Technical Data

<b>Weight/ bucket capacity</b>	Payload	4.000 kg
	Unladen weight	2.720 kg
	Struck level	1.600 L
	Heaped	2,3 m <sup>3</sup>
	Bucket system	hydraulically swivelling and tipping bucket by 180°
<b>Dimensions</b>	Total height with protection bar	2.940 mm
	Total height without protection bar	2.110 mm
	Total length	4.000 mm
	Total width	1.890 mm
	Ground clearance	360 mm
<b>Transmission</b>	Hydrostatic 4-wheel-drive with automotive control	
	speed I:	0-10 km/h
	speed II:	0-23 km/h
<b>Steering</b>	Hydraulic articulated steering acting over priority flow Steering angle 40° to each side	
<b>Axles / Brakes</b>	Front axle rigid, rear axle oscillating stored +/- 12°, maintenance-free-oil-bath multi-disc brake with automatic adjustment in the front axle, hydraulically applied locking brake acting over articulated shaft on front and rear axle.	
<b>Engine</b>	4 cylinder Kubota Diesel engine –water cooled- Output power 35,9 KW at 2.800 rpm.	
<b>Tyres</b>	Standard, 12.5/80-18 AS Profil	
<b>Tank capacity</b>	Fuel 50 L Hydraulic oil 40 L	
<b>Electrics</b>	12V electrical installation with main switch, control panel for engine water temperature, fuel and service hour meter, control lamps for motor oil; park brake, direction indicator, battery charging control, hydraulic filter, display for drive position	
<b>Standard Equipment</b>	Hydro sprung seat adjustable and collapsible, instrument panel lowerable and lockable with ignition key, tow-bar coupling, lighting system according to German traffic regulations, bucket from abrasion-proof fine-grain steel, EC type test approval, EC declaration of conformity, operator's manual / spare parts list	